

DCDC Converter F240 72V/14V/ 20A

This type of DCDC converter is widely employed in the electrical vehicle industry. It transforms the vehicle main battery voltage to the value necessary for isolated board electronics and for battery charging. An 8bit microcontroller is used for advanced protection and thermal management functions.

FEATURES:

- closed solid eloxal coated heatsink case
- designed to work with a board battery 12 V nom. at the output
- overheat protection - current limit decrease (no turn-off)
- short-circuit proof - indefinite
- water-resist - up to IP54*
- inrush current limit (NTC)
- effective input filter
- EMC ensured

SPECIFICATIONS:

Input voltage (nom.):	72 V (80 V)
Input voltage range:	50 V – 100 V
Shutdown voltage:	45 V
Recharging characteristic:	IU
Output voltage:	14 V (12.6V - 15.2V adjustable, factory set 13.8 V; V option only)
Cont. output current (35°C):	16 A
Cont. output current (60°C):	10 A
Max. output current:	20 A
Protections:	
Incorrect input connection & breakdown:	built-in fuse F 10 A
Overload and output short-circuit:	electronic output current limit, microcontroller
Overheat:	current limit decrease
Input undervoltage and overvoltage:	microcontroller
Output voltage ripple (0 – 50 MHz):	<50 mV RMS
Line / load regulation:	<1 %
EMC - conducted emissions:	EN 55022 level A
Safety:	EN 60950
Input to case isolation:	1.5 kV AC
Output to case isolation:	500 V DC
Efficiency (cont. current, typ.):	83 %
No load current consumption:	max. 25 mA
Ambient temperature range (full power):	-25 °C .. +35 °C (no convection)
Max. ambient temperature (derated power):	60 °C
Storage temperature:	-25 °C - +70 °C
Dimensions (WxHxD):	145x90x160 mm
Weight:	1.6 kg

* see Options.

Delivery time: cca. 2 - 4 weeks after receipt of the order.

DIMENSIONS:

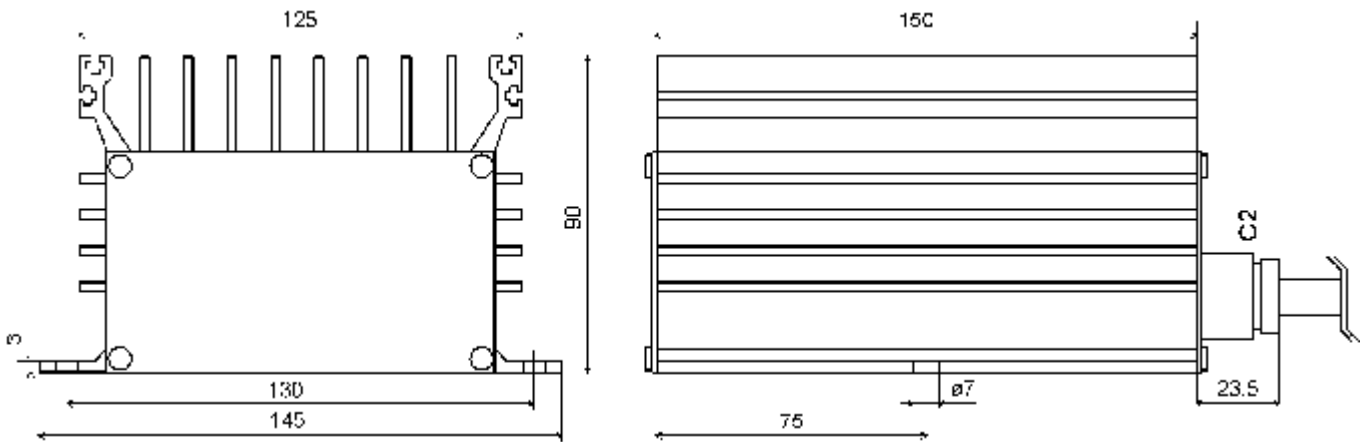

DESCRIPTION:

The converter is designed to work with the board battery at the output, which serves as an energy reservoir to supply temporary higher peak current than the converter output power capability. Therefore output voltage of the converter is set to the level sufficient for battery recharging (e.g. 13.8 V). The battery is recharged using IU characteristic.

The converter is protected against input reverse polarity and breakdown by an internal fuse. Use additional fuse at the output if necessary against output reverse polarity. The converter is short-circuit proof. When input voltage gets outside the limits, the converter stops working until input voltage returns to proper value (with small hysteresis). Response time is about 100 ms for overvoltage and 2 s for undervoltage protection.

An 8-bit microcontroller is used to control current limit and thermal management. The microcontroller constantly measures input voltage, output current and inside temperature. Output current limit is quickly (within seconds) decreased in case of short-circuit or harsh overload, until it is lowered down to 24 A (approx.). Then it slowly approaches maximal value (20 A). (Note: output current is decreased quickly down to 20 A at high inside temperature.)

In case of overheating (inside temperature rises because output power is beyond the converter's capability at given ambient temperature), the microcontroller reduces output current limit to protect the converter.

A green LED is placed under the window in the upper lid to indicate converter work (independent on accu connected). The LED shines when converter working.

INSTALLATION AND MAINTENANCE NOTES:

The converter is mounted by two screws preferably vertically (wires at the bottom) or horizontally (in this case the power capability of the converter may be slightly reduced). The case must be connected to the ground of the vehicle.

It's not recommended to mount the converter directly to the motor or to the gearbox. Case environmental protection must be considered in case of possible water influence.

When connecting the converter into the vehicle electric circuitry, it is necessary to keep proper polarity (+/- poles) !

The converter doesn't contain any moving parts, therefore no maintenance is required. It's recommended to check connector tabs and mounting screws at least once a year.

OPTIONS:

Cn - Case environmental protection

- C0 - IP40
- C1 - IP42 - silicon stick, moulded rubber grommet
- C2 - IP54 - silicon stick, compression type cable gland (PG11)
- D - "+D" wire for charging check light (12 V / 24 V, max. 5 W)**
- F2 – standard EMI suppression (EN 55022 – A), other upon customer’s request**

Ln - Indication LED under the window in the upper lid

- L1 - connected to output
- L2 - converter work indication (independent on accu connected)
- M3 – microcontroller used for advanced protection and thermal management functions**
- N - NTC inrush current limit in the input**

Sn - Built-in fuse

- S1 - input fuse 6x32mm / 500V AC
- S2 - output blade type Fuse-Link DIN 72581 (against reverse battery current)
- V - Pot for output voltage adjustment (under the window in the upper lid)**

Xn - Special requirements (connectors, mounting etc.)

- X0 - crimp ferrules ended wires
- X2 - standard screw terminals 6 mm²

others upon customer’s request.

Yn - alternative colors of wires

	+IN	-IN	+OUT	-OUT	+D	(K)	GND
<input type="checkbox"/> Y0	red	black	red	black	white	yellow	
<input checked="" type="checkbox"/> Y1	red	blue	black	brown	white	yellow	
<input type="checkbox"/> Y4	brown	blue	3xblack	3xblack			(gn.& yl.)